



# **Installation Manual: Radiant underfloor heating**

## **Heating Solutions International**



Dear customer,

Thank you for choosing our radiant underfloor heating system: easy to install and cost-efficient.

This manual contains all information you need for a successful installation. Please follow all instructions carefully to achieve the best result: comfortable and cost-efficient heating for years to come!

Your HSI-team



## Contents

Focus areas .....	3
Floor insulation.....	6
Installation: preparation and required materials / accessories .....	8
Preparations:.....	8
Accessories .....	9
Installation: installing the heating mats .....	11
Installation: making the electrical connections.....	13
Recommended materials .....	16
Thermostat .....	16
Snubber .....	16
Ground Fault Circuit Interrupter or Residual Current Device .....	16
Insulation material .....	16
Noise insulation.....	17
Annexes .....	18
Annex 1: Installation examples .....	19
Annex 2: Extending cold leads heating mats / thermostat .....	21
Annex 3: Typical wiring diagram (application relay) .....	22
Annex 4: Snubber .....	23
Annex 5: Registration resistance and insulation values .....	24
Annex 6: Trouble shooting .....	25
Annex 8: Warranty .....	26
Contact details.....	28



## Focus areas

Please read the below instructions carefully before starting the installation of the radiant underfloor heating mats.

**Important: all electrical connections must be performed by a fully certified electrician.**

### **DONT'S for**

#### **Heating mats**

- The heating mats may not overlap each other.
- The heating mats may not be folded or crinkled.
- The heating mats may not be cut to size.
- The heating mats, width 1,0 m<sup>1</sup>, consist of two halves of 0.5 m<sup>1</sup> connected to each other with a small cable. Both halves may not be separated.

#### **Installation**

- The heating mats must always be installed with the fibre glass net on top.
- Do not place heavy/sharp tools (or any other potentially damaging objects) on top of the heating mats.
- Do not walk unnecessarily on the heating mats.
- Do not install electrical cables or pipes under the floor together with the heating mats.
- Do not install heating mats when the room temperature is below -5°C (23°F).
- The heating mats are only suitable for indoor applications or in buildings.
- Do not install heating mats under walls, partitions, sanitary ware (such as baths) or heavy closets or cabinets.
- Do not install mats within 3 cm (1 inch) of any heat conductive building part, such as cold water pipes.
- Do not install mats within 15 cm (6 inches) of a second heat source e.g. (wood-burning) stove, fireplace, radiators or hot water pipes.
- Do not use a gap > 5 cm (2 inches) between individual heating mats.
- Do not install heating mats under a wooden floor thicker than 18mm (3/4 inch).
- Do not connect any other electrical appliance on the same electric fused spur or RCD unit of the heating system.
- Do not incorporate heating units below a height of 2.3 m into walls or into ceilings inclined at less than 45° to the vertical.



### **Insulation material and top layers**

- Do not use cellulose insulation.
- Do not put acoustic material between the heating mats and the wooden floor with a R-value of the acoustic material larger than  $0,014 \text{ m}^2 \text{ C/W}$  ( $0.08 \text{ ft}^2 \text{ h F/Btu}$ ).
- Do not use carpet underlay with thermal resistance  $> 0.08 \text{ m}^2 \text{ C/W}$  ( $0.8 \text{ Tog}$ ).
- Do not install the radiant heating mats under a carpet with a thermal resistance  $> 0.2 \text{ m}^2 \text{ C/W}$  ( $2.0 \text{ Tog}$ ).



## **ALWAYS**

- Apply floor insulation under the radiant heating mats to ensure the best possible heating output and to reduce the warm-up time and running costs. For more information: [www.hsi-heating.com](http://www.hsi-heating.com). Check with your installer to determine the R value of the sub floor insulation layer. If there is no insulation, or if the R value of the insulation layer is lower than  $0.1 \text{ m}^2\text{C}/\text{W}$  or 1 Tog, please read the insulation instructions on page 6 and act accordingly.
- Leave a minimum gap of 15-20 cm between the heating mats and walls. Subsequently install the heating mats at an equal mutual distance.
- When the heating mats are applied in a so called wet room (bathroom, sauna) and kitchen areas within 50 cm (20 inches) of sinks or any metallic kitchen appliance, grounding must be applied. Check your local guidelines for more regulations about the application of grounding in other rooms.
- The electric circuit that supplies electricity to the underfloor radiant heating system must be equipped with a 30 mA ground fault current interrupter (GFCI) or residual current device (RCD).
- Connect all cold wire leads from the HSI heating mats **in parallel** inside an electrical junction box or boxes.
- Ensure that the total current needed for all mats connected in parallel is not more than 80% of the listed amperage capacity of the electrical junction box and its power supply line and breaker. For advice consult your recommended installer/supplier.
- Provide each room with a HSI heating system with its own electrical junction box and control thermostat. Each thermostat has a maximum capacity of 15 Amps. If the amount of Amps in the room exceeds 15 Amps, divide the amperage over several thermostats or add a contactor between the heating mats and the thermostat.
- Connect the underfloor heating to (a) secured separate circuit(s).
- Wait for thin set/grout to dry properly before operating the system. Check the manufacturer's instructions for the drying period.
- Use a floating application of heating mats in wooden constructions to prevent damage to the heating elements and connections as a result of the movements of a wooden construction.
- Always apply a top layer with a minimum thickness of 5mm. Please contact HSI in case of a thinner top layer.

## **Note**

If you are installing a soft type of floor covering (carpet, vinyl or linoleum), cover the mats with a least 6mm (1/4 inch) self-levelling flooring cement / latex compound or with levelling plates. Make sure that all mats are properly fastened to the floor or insulation when using flooring cement or latex compound.

**All electrical connections must be performed by a fully qualified electrician.  
The installer must verify the conformance to all applicable codes or standards.**

**Important: The heating mats are Class II, double insulated. Protection: IPX7.**



## Floor insulation

Before starting with the installation of the radiant underfloor heating mats, the floor insulation must be in place. We strongly advise you to always apply floor insulation to achieve the best possible heating result.

Mentioned below you will find the guidelines applicable to the various insulation materials. We have included a summary of the most common combinations of insulation/top layers in annex 2. We also refer to our separate insulation overview containing a list of recommended suitable materials. All materials mentioned in this document are in conformity with the standards for compressive strength and R-value set by HSI BV.

### **Important:**

In case you have opted for a different type of insulation material not mentioned in our insulation overview, we strongly advise you to check the compressive strength, insulation value and the suitability to use the material in combination with IR underfloor heating with the respective supplier. We also advise you to use the available construction height to the full extent by filling the gap between heating mats/top layer and subfloor with a high R-value insulation material. We recommend a R-value of 2,5 m<sup>2</sup>K/W for new builds.

**In case floor insulation with a R-value of 2,5 m<sup>2</sup>K/W is being applied, the maximum power of the heating mats may not exceed 70W/m<sup>2</sup>. This recommendation applies to all types of flooring.**

### **Hard insulation material (a.o. for stone flooring)**

This material comes in plates, usually made from foamed polyurethane or polystyrene and should have compressive strength exceeding 2 kg/cm<sup>2</sup> (28 PSI). The R-value should minimally be in the range of 0.3 – 0.5 m<sup>2</sup>°C/W. Apply an insulation solution with the highest possible R-value.

### **Soft insulation material (for non stone flooring)**

The material is available in rolls and should have compressive strength of more than 0.02 kg/cm<sup>2</sup> (0.28 PSI). The R-value should minimally be in the range of 0.3 – 0.5 m<sup>2</sup>°C/W. Apply an insulation solution with the highest possible R-value.

We therefore recommend to combine hard insulation with a R-value > 1,0 completed with a soft insulation material.



**Important:**

When installing insulation material under carpeting, always make sure that the R-value of the insulation is at least the same or larger than the R-value of the carpet including underlay/levelling layer.

Clear the underfloor thoroughly before placing the insulation materials.

We have included the most common installation examples in annex one.

In case the top layer is glued (carpet, parquet flooring, laminate, vinyl, linoleum, PVC) the heating mats must be covered with at least a 6mm self-levelling flooring cement / latex compound or levelling plates. The type of levelling material depends on the top layer. See our separate insulation material overview.

You can also use comparable materials such as a self levelling latex compound provided this material has the same thermal conduction as the self levelling flooring compound. Consult your building material supplier for the best solution for your preferred flooring.



## Installation: preparation and required materials / accessories

Before starting the installation of the radiant underfloor heating mats, the following preparations must have been made and the following accessories must be at hand:

### Preparations:

1. Installation plan(s). Before installing, draw an installation plan showing the (numbered) mats, floor sensor, junction box(es) and thermostat location(s). The HSI mats should cover at least 80% of the floor area of the room when standard heating mats with a nominal power of  $150 \text{ W} / \text{m}^2$  are being used. Heating mats with a lower nominal power require a smaller coverage percentage.

Plan to use larger heating mats as much as possible and to apply smaller mats only as gap fillers. Place the mats in such a way that the connection cables (standard length  $5 \text{ m}^1$ ) are facing the thermostat.

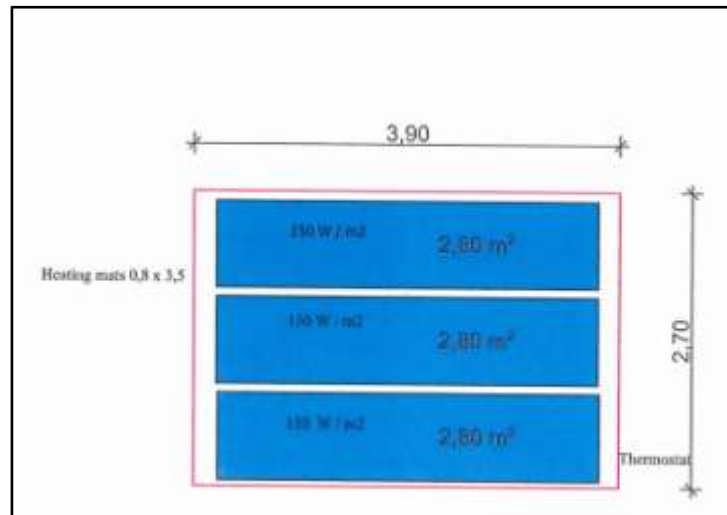

2. Determine the required power and the related number of (16) Amps (groups) for the underfloor heating. The underfloor heating must always be connected to (a) separate electric fused spur or RCD unit. Ensure that all electric provisions are being carried out by a certified electrician.
3. Install the electrical cable conduits, electrical junction boxes for cables and thermostat(s) as well as the power supply cable(s) to the thermostat location(s).  
Install the electrical junction box or boxes above floor level according to local safety and building regulations and codes.



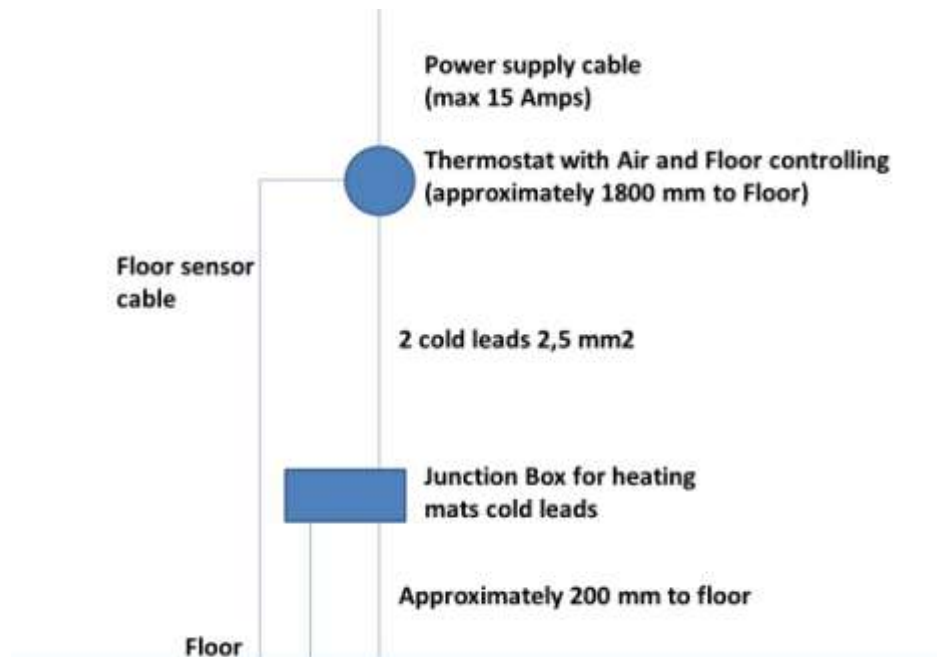

The electric conduits to the junction box and thermostat must be in accordance with the local applicable guidelines.

Install the thermostat as far as possible from any heat sources such as fireplaces, direct sunlight, windows, doors or anything that could possibly affect proper temperature readings. The suggested placement is 1.5 m (5 feet) above floor level; please take the local guidelines into account.

4. Apply the floor insulation.
5. Unpack the heating mats at least one day before installation and unroll them.

### Accessories

- One or more thermostats depending on the number of rooms where the heating system will be installed.
- In case the amount of Amps for one thermostat exceeds 15 Amps, a relay and possibly a snubber must be installed. See annex 4 and 5 for instructions.
- In case you want to avoid cutting and milling in walls, please provide the following materials: exposed junction box, cable tray and wall mounted outlet for thermostat.
- In case the heating mats are installed in a wet room, grounding must be applied via the existing floor reinforcement or by applying grounding mats (to be supplied by HSI BV).

**Notes**

- The heating mats are provided with 5 meters (16 feet) of electrical cold leads. These cold leads can be extended should this be required. Ask your electrician to extend the respective cold leads.
- The floor temperature sensor of the thermostat can also be extended should this be required. Ask your electrician to extend the connection cable should this be necessary.



## Installation: installing the heating mats

1. Ensure that the floor base is dry, frost free, fixed, load bearing, firm stable and clear of dust, dirt, oil, grease, anti-stick substances and debris. Also ensure that the floor meets all applicable guidelines and standards, national and European as well as trade guidelines.  
Clean the floor base and/or insulation material thoroughly.



2. Apply insulation material (depending on top layer).



3. Place the heating mats on the insulation material conform the installation plan with the heating ribbons facing down and the fibreglass facing up. The heating mats can be placed up to a wall but this is not necessary. We advise to use a gap of max. 5 cm (2 inches) between the heating mats and a gap between the walls and the heating mats of approx. 15-20 cm. Make sure that the cold leads of the mats are on the side of the mat which is closest to the location of the electrical junction box.



4. Ensure that the heating mats are completely flat, stretch them and secure the mats onto the base. When applying soft insulation material, the heating mats can be secured by using Duct tape. Attention: do not use aluminium tape. The heating mats can also be secured by applying glue between the heating wires (apply only on the fibreglass net – do not glue the heating wires).

When applying tiles, you can place the heating mats in the flexible tile glue.

It is also possible to secure the heating mats with screws or with a tackler. The screws/staples may only be applied on the glass fibre net and not on the heating elements.





5. Place the cold leads of the mats between the mats towards the junction box. Try to place the cold leads so that they do not cross each other.

**Important:** Ensure that the cold leads of the mats do not cross the heating mats.

Create a recess in the insulation material.



6. Since the cold lead connector is slightly thicker than the rest of the mat, create a slight groove in the insulation material under the connector to ensure that the heating mat lays flat. If any cold leads cross, create a groove for the cold leads at the point at which they cross.



7. Provide grounding when the heating mats are applied in wet rooms.



8. Mark each pair of cold leads coming from the same mat with a number. Place a small sticker with the number of each pair of leads close to the end of the lead.





## Installation: making the electrical connections

### Important

All electrical connections must be performed by a fully qualified electrician.  
All connections must be tightly screwed to ensure good electrical contacts.  
Always apply a thermostat with a floor temperature safety sensor.

1. Install the thermostat in conformity with manufacturer's instructions.

### Important

Each thermostat has a maximum capacity of 15 Amps. If the amperage in the room is larger than 15 Amps, divide the amperage over several thermostats or add a contactor between the mats and the thermostat(s). Some thermostats may also require a snubber. See annex 4 and 5 for more information).

2. Connect the floor temperature safety sensor to the thermostat through a conduit and install the sensor between two heating mats, at least 50 cm (20 inches) from the wall. Ensure that the sensor does not touch any of the heating ribbons. Place the sensor between the largest heating mats. In case there is only one heating mat applied, the sensor must be placed next to the heating mat at a distance of 2-3 cm (1 inch).



3. Measure the resistance of the heating system and record the value. Verify that the value you measure is in line with the resistance value that is printed on the specific heating mat.





4. When you are installing hot heating mats in wet areas (such as bathrooms, saunas and kitchen areas within 50 cm (20 inches) of sinks or any metallic kitchen appliance, grounding must be applied. Grounding can be applied via the existing floor reinforcement or by applying grounding mats (to be supplied by HSI BV). Grounding nets must be applied as follows:
  - a. Install the grounding net on top of the heating mat. The electrical wire of the grounding net should not coincide with the heating mat cold lead. Make sure that the grounding net stays in place by mounting it onto the flooring/insulation material.  
OR  
Apply a thin layer of levelling flooring cement or latex on top of the heating mats, install the grounding net and then again apply a thin layer of levelling flooring cement or latex on top of the grounding net. The electrical wire of the grounding net should not coincide with the heating mat cold lead.
  - b. Route the electrical wire of the grounding net to the same electrical junction box as the cold leads of the heating mats.
  - c. In the electrical junction box, connect the electrical wires of the grounding to the ground lead (green/yellow) of the power supply of the house.
5. Feed the cold lead of each mat - **in parallel** – to the electrical junction box. Make sure that you can see the sticker with the numbers of the leads. If necessary, shorten the leads, but make sure the sticker with the leads' numbers are affixed to the shortened lead. If necessary you can extend the cold leads, see instruction in annex 2.
6. Expose the conductor of each lead and mark each pair of cold leads coming from the same mat with a number.
7. Connect all leads of the same colour.
8. Insert each coloured lead to one connector in the junction box.

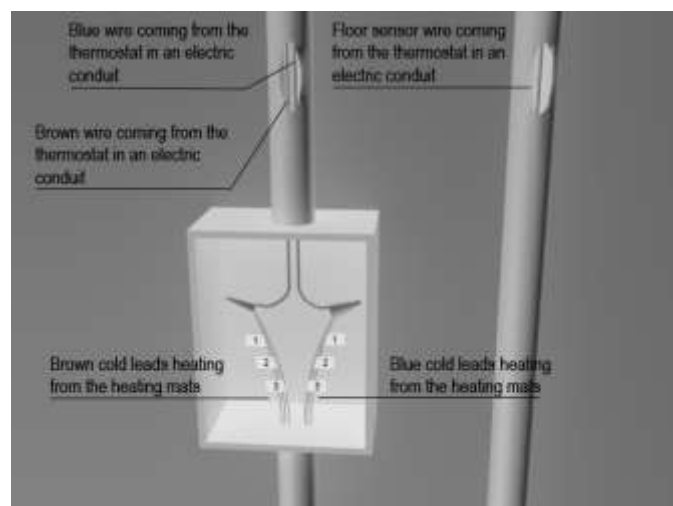



9. Optional: you can apply a screamer during installation (supplied by HSI BV) to check the operation of the heating mats. Instructions are included.
10. Place your floor covering. If you are installing a glued type of flooring (carpet, wood, vinyl or linoleum), first cover the mats with at least 6mm (1/4 inch) self levelling flooring cement. (You can also use similar materials, like Latex based self levelling compound, as long as they have the same or better thermal conductivity as the self levelling flooring cement). Consult your local construction material dealer regarding the right material for your type of floor.  
**Important:** if you are installing a glued type of floor covering, or using thin-set or grout or tile adhesive, do not switch on the heating system again until the glue, thin-set, or grout or tile adhesive is dry. Consult the manufacturer of the material used to determine the amount of drying time needed.
11. Run an isolation test of the heating mats. Record all values.  
This insulation value must be indefinite.



12. Connect the heating mats and the floor sensor to the thermostat in conformity with the wiring diagram. See annex 3 and 4 for more information on the application of a relay and/or snubber. Connect the thermostat to the supply voltage, switch on the thermostat and check the heating mats on correct operation (getting warm).
13. Place the following label on the electrical junction box or boxes indicating that an underfloor heating system is installed in the room.





## Recommended materials

### Thermostat

We recommend the application of a thermostat provided with a floor sensor. HSI BV offers a variety of models with manual, automatic or remote control. All thermostats on offer are provided with a floor sensor.

HSI BV supplies the following models:

- FIT3U (Eberle)
- TH232 (Aube)
- MiGenie: G104M (Drayton).

The thermostats are provided with the following control modes:

- F, based on floor temperature
- AF, based on ambient temperature with a floor safety sensor against overheating with the floor temperature prevailing.
- A, based on ambient temperature.

The required control mode is set on the thermostat.

#### Note:

- HSI advises to use the F-mode in wet rooms and in so called traffic spaces (e.g. entrance, landing) with an open connection to other spaces / floors. This mode is also recommended when a second heat source is being used in a room (e.g. fireplace, wood burning stove). When the second heat source is not in use but heating is required, you can apply the AF mode.
- HSI advises to apply the AF mode for all other rooms.

### Snubber

We advise model EVOX MMK RD 47nK630. This product is included in our product range.

### Ground Fault Circuit Interrupter or Residual Current Device

Consult your local dealer regarding the applicable GFCI or RCD.

### Insulation material

Please review our separate overview of recommended insulation materials for more information on suitable materials in combination with various types of floor covering. All materials included in this document meet the requirements for compressive strength and R-value set by HSI BV. Annex 1 includes the most applied combinations.





## Noise insulation

To prevent traffic noise on wood (parquet) flooring, sound protection materials must be used. Typically soft insulation materials also possess good sound prevention qualities. In cases where the soft insulation does not provide adequate sound protection, additional layers of the acoustic material between the heating mats and wooden floor can be used. The R-value of this layer must be lower than  $0,014 \text{ m}^2 \text{ }^\circ\text{C/W}$ .



## **Annexes**

Annex 1: Installation examples floor insulation / heating mats / top layers

Annex 2: Extending cold leads heating mats / thermostat

Annex 3: Typical wiring diagram (application relay)

Annex 4: Snubber

Annex 5: Registration resistance and insulation values

Annex 6: Solving problems

Annex 7: Warranty

Annex 8: Contact details



## Annex 1: Installation examples

### Under tiles in dry surroundings\*:



\* Grounding must be provided when the IR heating mats are applied in a wet surrounding.

### Laminate, wood, parquet flooring (non-glued) in dry surroundings:



### Carpet, vinyl, PVC, cork and linoleum in dry surroundings (non-glued or glued):





### Parquet glued / Poured floor - in dry surroundings



Poured floors:

Please check the application of levelling plates with the supplier of the poured floor.

#### Remarks:

- \* In wet surroundings, ensure that grounding is applied.
- \*\* Please check local building codes and regulations and act according to them if they contradict the instructions above.
- \*\* Do not use carpet underlay with more than 0.8 Tog.
- \*\* Use a Hessian backed carpet with a lower than 2.0 Tog. Always ensure that the Tog value of the insulation is at least the same as the carpet.

Review our insulation material overview for suitable and recommended insulation materials.



## **Annex 2: Extending cold leads heating mats / thermostat**

### **Extending cold leads heating mats**

The IR heating mats are provided with two 5 meter cold leads. In practice, these cold leads will need to be shortened or sometimes be extended. Any extension must be made by a qualified electrician. Use the remaining cold leads of shortened leads for extensions when possible.

Instructions for extending cold leads:

#### **Step 1**

Expose 6mm of the wires edges on the extension and the original wire.

#### **Step 2**

Insert the exposed edges into a copper crimp sleeve (standard sleeve 2.5mm diameter), then crimp the edges using a crimping tool.

#### **Step 3**

Slide the shrink tube over de crimped copper tube.

#### **Step 4**

Use a heat gun to shrink the tube.

### **Extending sensor cable thermostat Aube TH232**

The sensor cable can be extended with 2x0.75, 2x0.8 or 2.1 mm<sup>2</sup>.

Ask your qualified electrician to perform the cable extensions.



### Annex 3: Typical wiring diagram (application relay)

## Typical Wiring Diagram

Option A - for circuits less than 16 amps

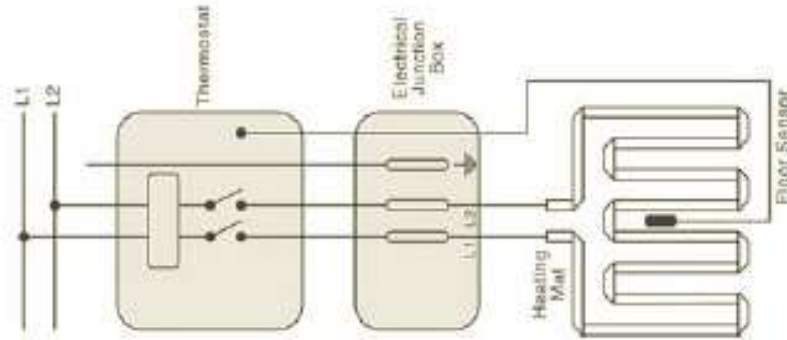

Option A - for circuits less than 16 amps

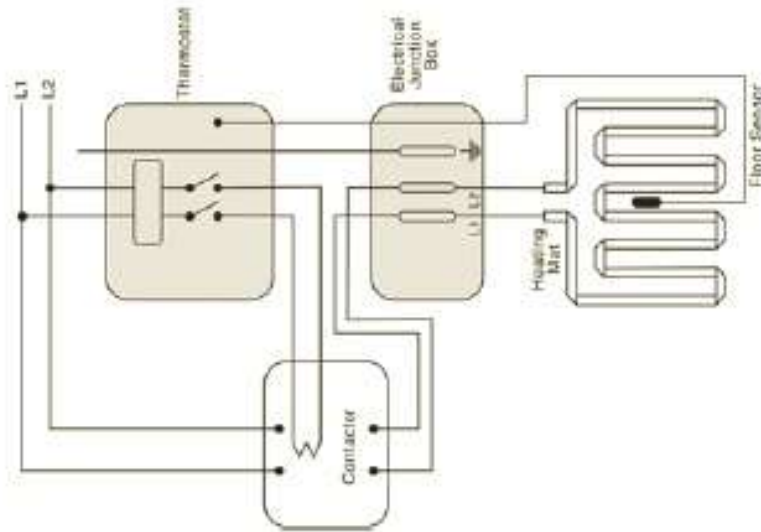



## Annex 4: Snubber

### Important

When the total wattage at peak load of all heating mats connected to one thermostat exceeds 3450 Watt (15 Amps), the Aube TH232 thermostat also requires the installation of a snubber besides the required relay. The snubber capacitor is connected to the coil contacts of the contactor (A1 and A2). A correct connection has no impact on the operation of the thermostat (see diagram).

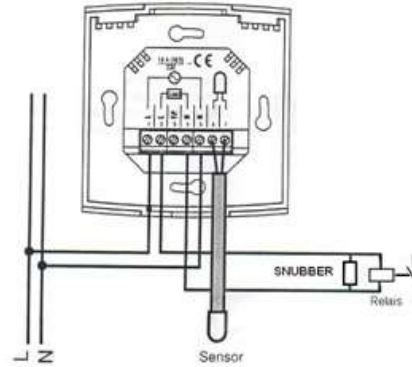



## Annex 5: Registration resistance and insulation values

### Project details

Owner	
Address	
Zip code and residence	
Room thermostat 1	
Room thermostat 2	
Room thermostat 3	
Room thermostat 4	
Room thermostat 5	
Room thermostat 6	

### Installer

Company	
Employee	
Date	
Signature	

### Metingen

Thermostat no	Mat no	Width mat (cm)	Length mat (cm)	Nominal Resistance	Measured Resistance	Measured Insulation

We advise you to number the heating mats on the layout plan and to maintain both documents.





## Annex 6: Trouble shooting

The heating mats are designed to be maintenance free. Failures may occur as a result of damage to the heating elements during installation. The following table provides a list of possible problems you may encounter. For each problem, possible causes and solutions are provided. Consult a fully certified electrician when necessary.

Problem	Possible cause	Solution – Action
No heat in the entire room/floor	Main circuit breaker is off  RCD tripped    Faulty thermostat	Reset the main circuit breaker. If the breaker cannot be reset, verify that it can handle the heating system load. Reset the RCD. If the RCD cannot be reset, disconnect the wires from the RCD and try to reset the RCD. If it does not reset, replace the RCD. If it does not reset it means that there is a fault with one of the heating mats. Check the insulation value of the heating mats to identify the faulty mat: disconnect it and consult your HSI representative. Check that the thermostat settings (on/off position, temperature setting and clock setting) are correct. Check if all the settings are correct, replace the thermostat. Also check any fault notifications on the thermostat display.
No heat in part of the room/floor	A heating mat is disconnected A heating mat has short-circuited	Check the heating mat connections in the electrical connection box. Tighten any loose connections. Check the electrical resistance between the cold leads. If there is a short-circuit, contact your HSI-dealer.
Overheating in the entire room/floor	Thermostat setting is too high Faulty thermostat Wrong power line supply: 230/240 V instead of 110 V 380 V instead of 230 V	Set the thermostat to a comfortable level. Replace the thermostat. Make sure you are using the correct line voltage. Rewire if necessary.
Overheating in a part of the room/floor	Thermal blocking	Avoid placing floor level furniture (e.g. futons and mattresses) on the floor.
Room not warm enough	Thermostat setting is too low Floor sensor is under thermal blocking Floor sensor setting is incorrect Improper insulation under the heating mat Initial heat loss calculations were wrong	Set thermostat to a higher temperature. Avoid placing floor level furniture (e.g. futons and mattresses) above the floor sensor. Raise the floor sensor setting.  Requires system upgrade.  Requires system upgrade.
Different level of heat in the room	Wrong connection – possibility of some mats were connected in series instead of parallel	Open the connection box and reconnect the mats correctly.
Fault notification on thermostat	Temperature too low/high Defect built-in sensor Problem in floor sensor circuit	Check manual thermostat and solve problem. Contact HSI BV for repeating fault notifications.
No info on thermostat display / connection cables are burned through	Wrong connection – possibility that mats were connected in series instead of parallel Total amperage for one thermostat exceeds 15A	Open the connection box and reconnect the mats correctly. Replace faulty thermostat.  Install a relay (and snubber) or install an extra thermostat and divide the connected heating mats. Replace faulty thermostat.



## Annex 8: Warranty

Heating Solutions International ("HSI") hereby guarantees to you, the purchaser of the HSI heating mats (the "Product") to which this warranty (the "Warranty") is attached that the Product will be free from defects in materials and workmanship, for a period of ten (10) years from the date such Product was purchased (the "Warranty Period"); provided that the Product is installed in accordance with: (a) the accompanying HSI Installation Manual; (b) any special written design or installation guidelines provided by HSI; and (c) all applicable laws, rules, regulations, codes and standards applying in the territory in which the Product is installed, including without limitation, all applicable local building and electrical codes.

This warranty is transferable to subsequent owners of the Product.

Thermostats or other accessories sold under the HSI name are warranted for parts and materials for one (1) year.

If HSI finds the Product to be defective as a sole result of defects in material or workmanship – then, during the Warranty Period, upon receipt of due notice from you and subject to the terms of this Warranty – HSI shall: (1) repair the product; (2) refund the cost for repair of the Product, as well as labour and materials required to repair the Product; (3) replace the Product, or parts thereof; or (4) refund part or all of the original purchase price. The option to repair, replace or pay a refund shall be at HSI's sole discretion. HSI will not assume responsibility for the cost of flooring materials, or the cost to remove and replace flooring materials.

This Warranty does not cover and HSI shall not be held liable for any of the following damages: (a) damages caused, wholly or partially, due to abuse, misuse, negligence, application and/or maintenance not as recommended by HSI and/or not as set forth in Section 2 above; (b) damages to the Product caused by workers, visitors on the job site, or post-installation work; (c) damages caused by accident, natural disasters (such as fire, floods, lightning, etc.) force majeure, sabotage or any unforeseen circumstances; (d) special, indirect, incidental, secondary, consequential or any other damages of any nature arising out of ownership or use of the Product including inconvenience or loss of use.

This Warranty is null and void if the owner, or designated representative, attempts to repair the Product without receiving prior authorization from HSI. Upon notification of a real or possible problem, HSI will issue a written Authorization to Proceed under the terms of this Warranty.

HSI disclaims any warranty not provided herein, including any implied warranty of the merchantability or implied warranty of fitness for a particular purpose. There are no warranties, which extend beyond the face of this document. No agent or representative of HSI has any authority to extend or modify this warranty unless such extension or modification is made in writing by a corporate officer.



Due to differences in building and floor insulation, climate, and floor coverings, HSI makes no representation that the floor will achieve any particular temperature, or temperature rise. Certain standards listing requirements limit the heat output of underfloor heating mats and as such, users may or may not be satisfied with the floor warmth that is produced.

HSI does warrant that all Products will produce the rated watt output listed on the Product nameplate, when operated at the rated voltage.

If your country does not allow the exclusion or limitation of incidental or consequential damages, does not allow limitations on how long implied warranties may last, then the aforementioned limitations or exclusions may not apply to you. This Warranty gives you specific legal rights. You may have other rights, which vary from country to country.

Any claim under this Warranty must be made in writing including the original invoice and posted to HSI's address detailed below within thirty (30) days from the date of the discovery of the defective Product, and it must reach HSI not later than thirty (30) days from the end of the Warranty Period. All defective Products and/or parts thereof must be retained until receiving further instructions from HSI. HSI may demand the shipment to its facilities, of the Product claimed to be defective or of a sample thereof for assessment and evaluation, prior to repairing, replacing or paying a refund.

The staff at HSI is available to answer any questions regarding the proper installation or application of the Product. You can find your HSI dealer at the following website: [www.hsi-heating.com](http://www.hsi-heating.com). If you have any questions regarding the installation procedure, or if the Product appears to be damaged, please contact your HSI dealer or HSI representative before proceeding with the installation or proposed repair.

Effective: June 2010

This warranty applies to all products purchased after this date.

Heating Solutions International  
Molendijk/Zuid 23c, 5482 WZ Schijndel, The Netherlands  
P.O. Box 47, 5258 ZG Berlicum, The Netherlands

T 088 1300 200

E [info@hsi-heating.com](mailto:info@hsi-heating.com)

W [www.hsi-heating.com](http://www.hsi-heating.com)



## Contact details

Heating Solutions International  
P.O. Box 47  
5258 ZG Berlicum

T 088 1300 200

E [info@hsi-heating.com](mailto:info@hsi-heating.com)

W [www.hsi-heating.com](http://www.hsi-heating.com)